



**11900 Riverwood Drive
Burnsville, MN 55337**

Phone: 952-894-6637

Fax: 952-894-0750

Email: info@ventaire.com

Website: www.ventaire.com

PRODUCT GUIDE FOR

TMHR Motorized

Hose Reel

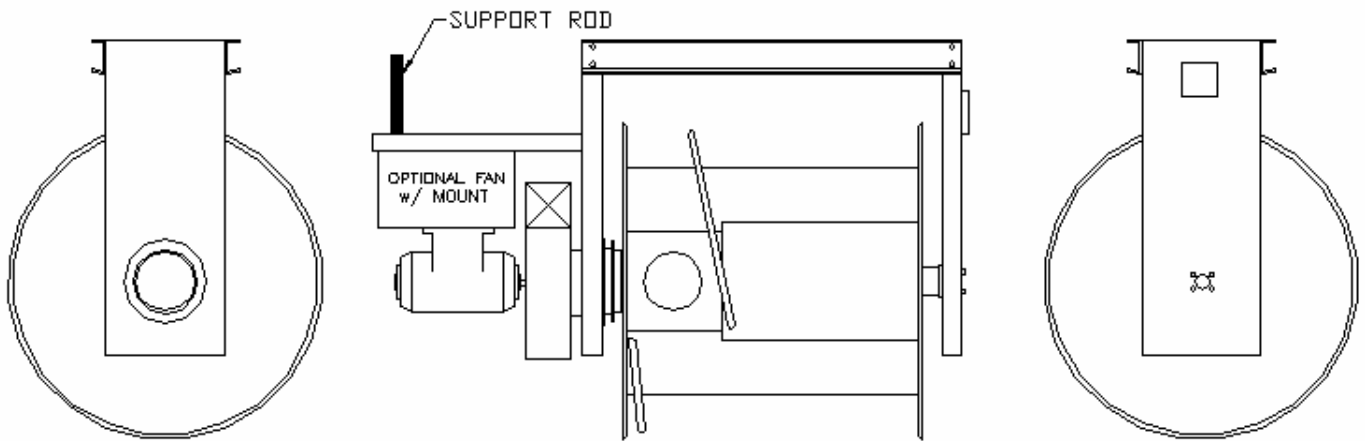

FIG 1

INTRODUCTION

1. Prior to the installation inspect all components received for shipping damage. If damage occurred contact your Ventaire representative for assistance.
2. Read **ALL** the instructions before proceeding with any installation, operation, or maintenance.
3. The hose reel is supplied with a temporary shipping bolt located near the limit switched on the hose reel's motor. This bolt should not be removed until the reel is rigidly mounted and must be removed before powering reel.

INSTALLATION

1. Raise the hose reel off of the ground with lifting mechanism (i.e. forklift, crane, etc.) and mount it to the ceiling, wall, or floor at desired location using 1/2" bolts in all four corners. The hose reel should be oriented as in FIG 1 with the hose reel base on top.

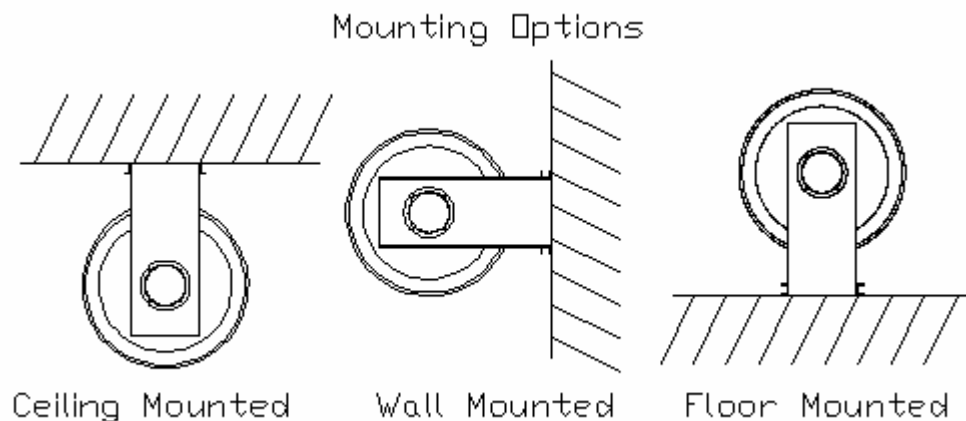

FIG 2

2. Attach the flanged reducer to the reel by screwing the flange to the angle ring located at the outlet.

CAUTION: Do not drill through the axle pipe when mounting the reducer flange. This will prevent reel movement.

3. Connect the rigid duct to the reel outlet or fan outlet using industry standard methods.
4. Remove the shipping bolt connecting the hose reel drum flange to the rectangular support bracket.
5. Remove the control box, wall box, and transformer covers (if applicable.) Wire the power supply, transformer, control box, and wall control box according to the attached wiring schematic.
6. Test the up and down buttons to ensure the proper installation and wiring has been preformed. Adjustments to the limit switches will be performed after the tubing is attached to the reel.

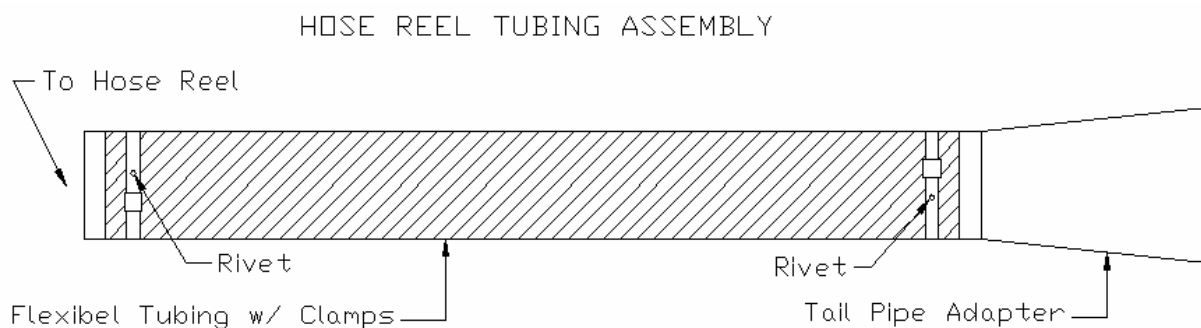

FIG 3

7. Assemble the flexible tubing assembly as shown in FIG 3.
8. Fasten the Tailpipe adapter to the other end of the flexible tubing using the provided hose clamp. To ensure a rigid connection is established, drill and rivet the connections through the hose clamps.
9. Attach the flexible hose to inlet elbow using the hose clamps provided. It is recommended to rivet the flexible hose to the elbow through the clamp to ensure a rigid connection.
10. Replace all of the covers.

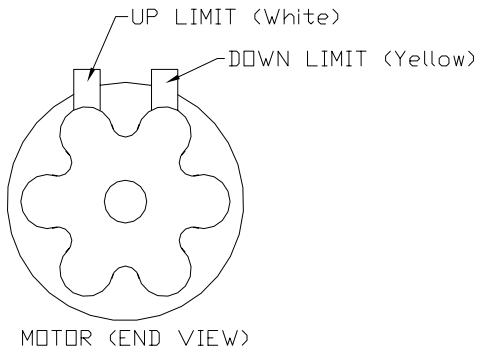

FIG 4

11. The limit switches are factory adjusted, but may require fine tuning to ensure that the reels function correctly. The limit buttons are located at the end of the motor. The buttons are white (UP) and yellow (DOWN) in color. The limits are easily adjusted. Adjustment is performed by depressing the button and activating the reel. When the hose is at the desired height, release the button and the limit is set. Perform this for both directions. As a rule of thumb, a reel with 6" dia x 25' of hose will need to rotate approximately 3-1/4 turns. For every 5' of hose added or subtracted increase the revolutions by 1/2 of a turn.
12. Check several times to make sure that the limits are working. If not, repeat the above limit setting procedures. If problems are still present, stop, discontinue and contact the representative.

ELECTRICAL CONNECTIONS (For Optional Direct Mount Fan):

10. Before connecting the motor to the electric supply, check the electrical characteristics as indicated on motor nameplate to ensure proper voltage and phase. Remember that a single-phase motor is connected only to a single-phase voltage supply (three phase, three phase supply).

CAUTION: A ground wire must be run from the blower motor housing to a suitable electrical ground such as a properly grounded metallic raceway or a ground wire system.

11. Inspect for damage resulting from shipment. Also, the entire fan must be completely dry prior to performing any electrical work.
12. It is recommended that in every motor connection, an overload device be installed between the current supply and the motor to protect the motor from under-voltage conditions and motor overloads.
13. Follow the wiring schematic located on the motor of the fan for specific wiring instructions.
14. After the electrical connections are completed, apply just enough power to start the unit. Be sure that the rotation of the wheel is correct as indicated by the directional arrows on the unit. Rewire until the correct rotation has been achieved.

15. Apply full electrical power. With the air system in full operation and all ducts attached, measure the current input to the motor and compare with the nameplate rating to determine if the motor is operating under safe load conditions.

OPERATION

Complete operation of the motorized hose reel can be accomplished in five easy steps. Please see the Installation instructions for complete installation and limit adjustment instructions.

1. Press the DOWN button to unroll the hose far enough so the tailpipe adapter can be attached to the exhaust pipe of the vehicle.
2. Once the tailpipe adapter is connected to the exhaust pipe, open any applicable air shut-off devices and turn on the exhaust fan.

When finished simply:

3. Disconnect the tailpipe adapter from the vehicle and press the UP button to roll up the tubing onto the reel.

MAINTENANCE

Maintenance is very routine and uncomplicated. Follow the steps below to ensure a unit that is both effective and efficient.

1. Routinely check the flexible tubing and connections for excessive wear to ensure proper airflow. Replace if necessary.

Operational Warning! Do not allow too much flexible tubing to roll onto the hose reel. This may cause damage to the hose reel, flexible tubing, and/or the tailpipe adapter.

2. Routinely check the hose reel mount (to the rigid duct and the ceiling) to provide safe operation. Tighten loose connections if necessary.
3. Follow the exhaust fan maintenance instructions provided by the manufacturers.
4. Adjust motor limit switches as needed per installation instructions.

For systems with infrared controls:

5. Routinely clean the infrared sensors on the hose reels.
6. Take caution not to drop or damage the infrared remote control.

7. Keep the infrared remote clean and replace batteries to promote maximum transmission effectiveness.

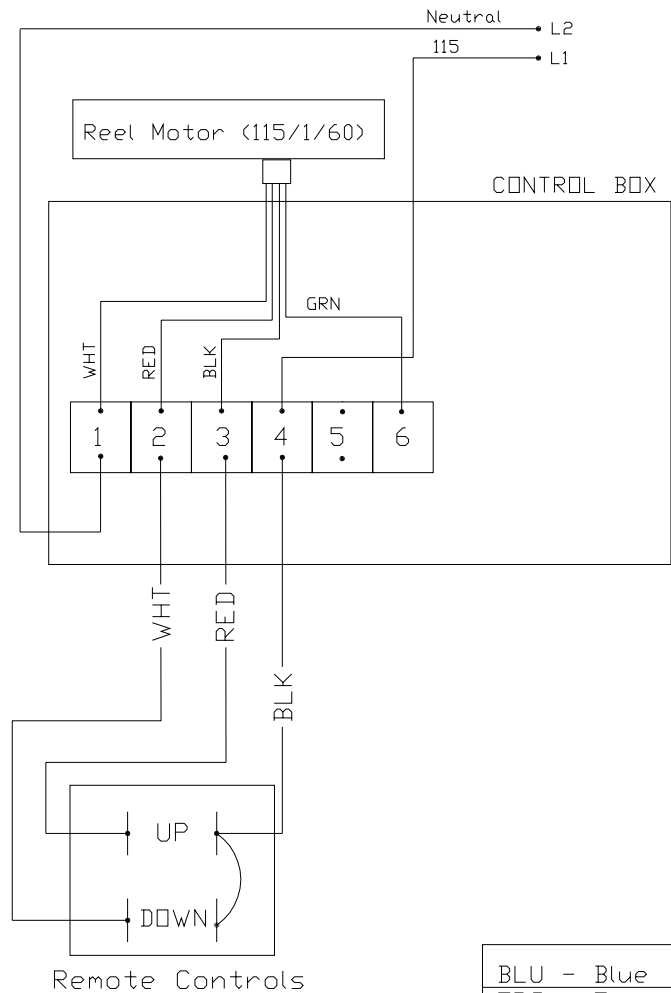

BLU - Blue	BLK - Black
ORG - Orange	GRN - Green
WHT - White	YEL - Yellow
BRN - Brown	

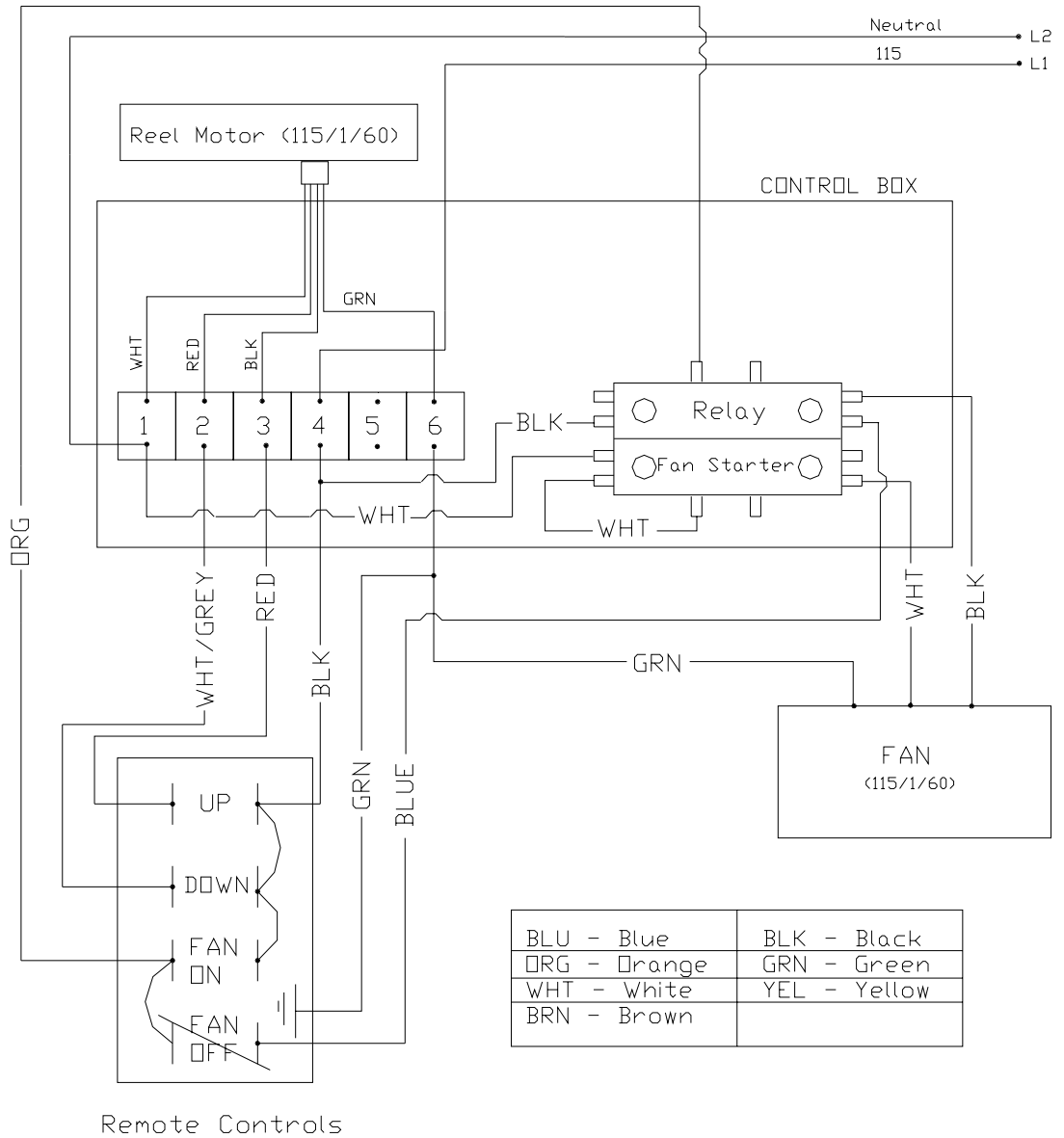

WIRING DIAGRAM

TMHR – Hose Reel
w/ 2 BUTTON CONTROL,
FAN MICROSWITCH, & FAN

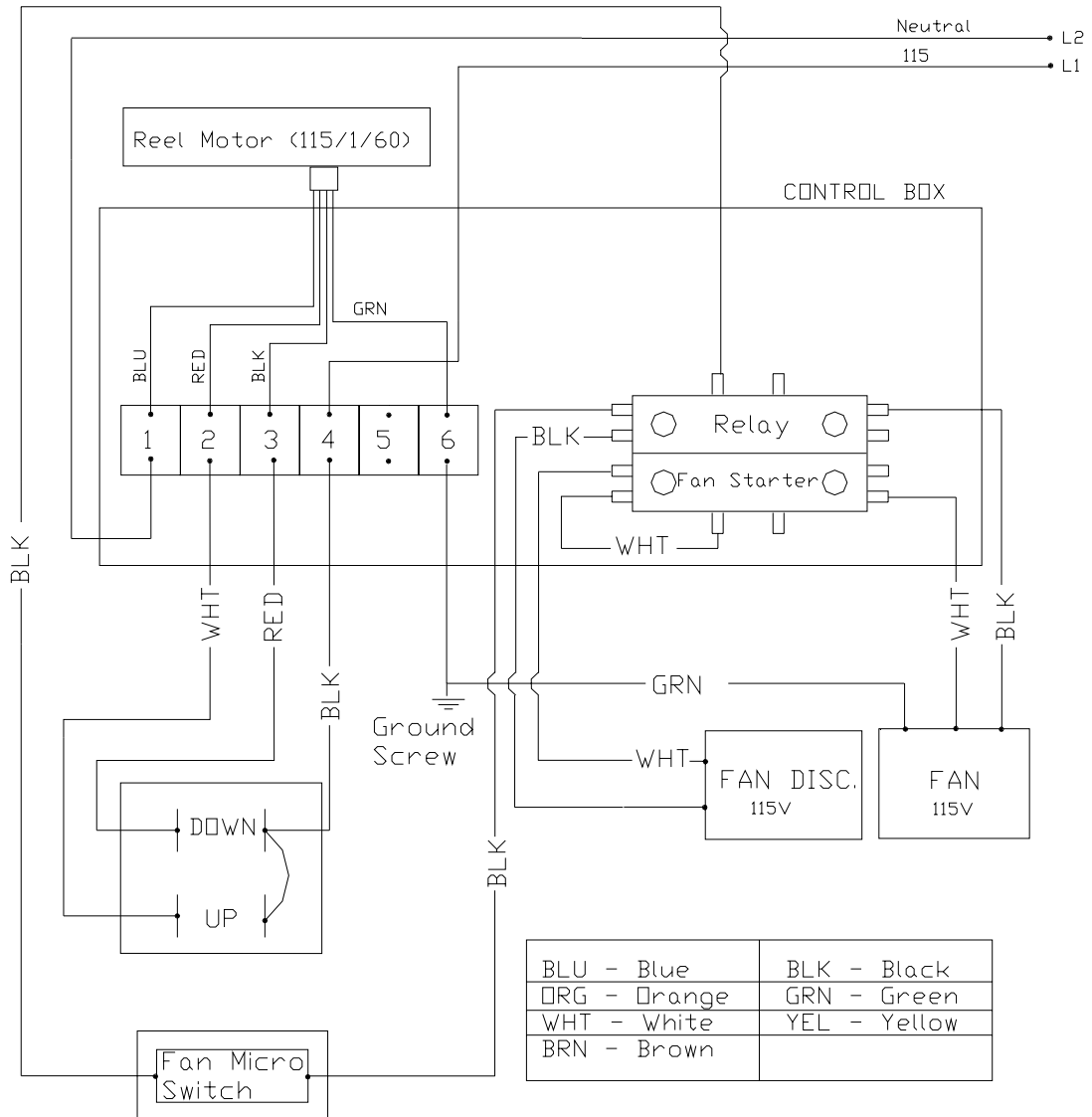

WIRE-TMHR-2B-MKS-DIS.DWG



11900 Riverwood Drive
Burnsville, MN 55337
Phone: (952) 894-6637
Fax: (952) 894-0750
Email: info@ventaire.com

12-MONTH WARRANTY

VENTAIRE warrants their products, to the original purchaser, to be free from defects in material and workmanship under normal use and service (except for those cases which buyer supplied materials are used) for a period of 12 months from the original date of shipment. During the warranty period, **VENTAIRE**, will at its option, repair, replace, or issue credit for any components that are deemed defective by **VENTAIRE**.

Buyer's failure to pay the full amount due within (60) days of invoice shall release seller from any and all liability or obligation to any warranty.

Before returning equipment for repair or replacement, a **Return Authorization Number** must be obtained from **VENTAIRE** (952-894-6637.) The **Return Authorization Number** must be written on the outside of all shipping cartons. Items returned without a **Return Authorization Number** will be refused. Items returned should be in original condition in which it was received and must be accompanied with a written explanation of the reason(s) for their return.

This warranty does **not** cover damage caused by accident, misuse, misapplication, or unauthorized service modification.