

PROJECT:

LOCATION:

ENGINEER:

SALES ENGINEER:

ARCHITECT:

CONTRACTOR:

DATE:

ALL DIMENSIONS ARE IN INCHES

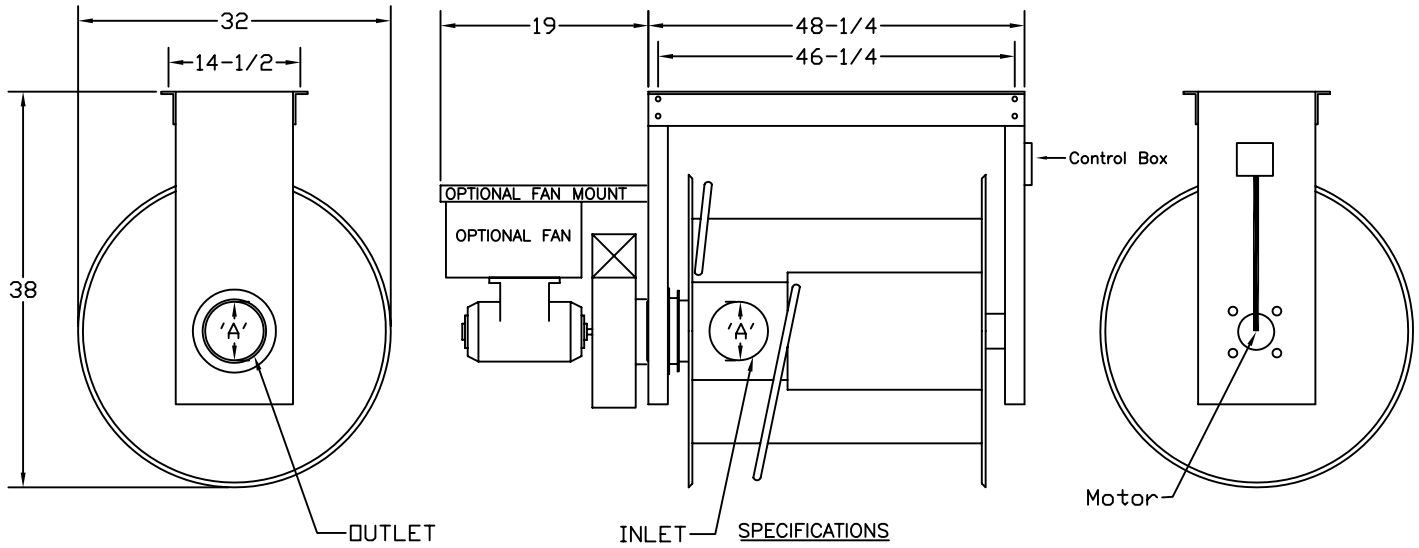

MODEL	TUBING DIAMETER: 'A'	FLEX CAPACITY STD * (FT)
TMHR80	8"	25'

**SPECIFICATIONS**

- DRUM: 14 GA. STEEL
- DRUM SIDE PLATE: 16 GA. STEEL
- FRAME: 12 GA. STEEL
- BEARING: SLEEVE BEARING
- MOTOR - 110/1/60, 3.8A - 430W
  - Totally Enclosed Construction
  - Built in Brake & Limit Switches
  - Speed: 14 RPM
  - Thermal Overload Protection
- WALL MOUNTED MOMENTARY CONTACT PUSH BUTTON SWITCH:
- MOMENTARY CONTACT PUSH BUTTON SWITCH: RAISE & LOWER
- OPTIONS:
  - 3-BUTTON PENDANT, 4-BUTTON PENDANT, and INFRARED REMOTE
  - MICROSWITCH FOR FAN/DAMPER CONTROL (MODEL MKS)
  - FAN (MODEL PW SHOWN) W/ MOUNT (MODEL FRM)

Four 1/2" Mounting Holes in 14.5" X 46.25" Rectangular Pattern

**SCHEDULE**

ITEM	QTY	MODEL	TUBING DIAMETER	FLEX LENGTH	REFERENCE

**NOTES**

- Tailpipe adapter and flex specified on separate drawings.
- \* Consult factory for larger capacities or nonstandard diameters.