

PROJECT:

LOCATION:

ENGINEER:

SALES ENGINEER:

ARCHITECT:

CONTRACTOR:

DATE:

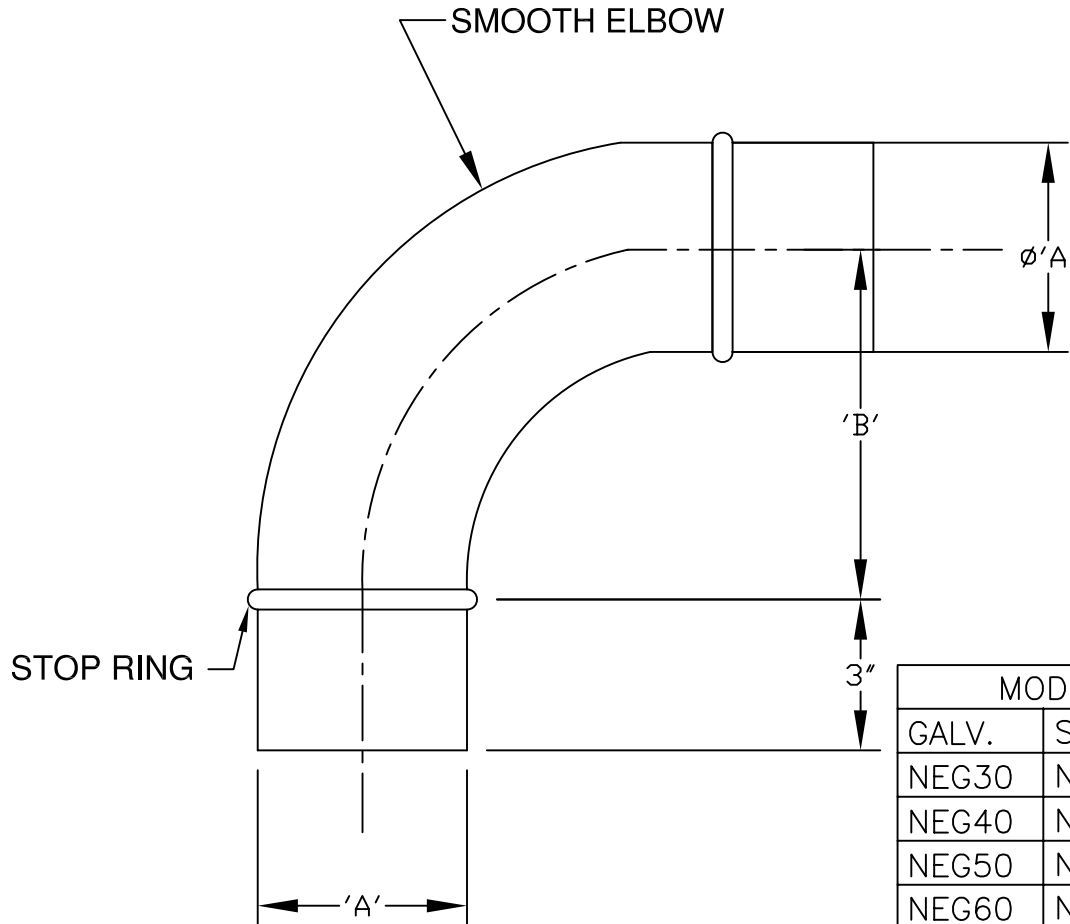

MODEL		'A'	'B'
GALV.	S.S.		
NEG30	NES30	3	4-1/2
NEG40	NES40	4	6
NEG50	NES50	5	7-1/2
NEG60	NES60	6	9
NEG80	NES80	8	12
NEG100	NES100	10	15

SCHEDULE

ITEM	QTY	MODEL	REFERENCE

NOTES

ALL DIMENSIONS IN INCHES
 DIE STAMPED SMOOTH BORE.
 CONSTRUCTED OR 20 GA. GALVANIZED STEEL. 304 STAINLESS STEEL OPTIONAL.