

**PROJECT:**

|            |             |                 |
|------------|-------------|-----------------|
| LOCATION:  | ENGINEER:   | SALES ENGINEER: |
| ARCHITECT: | CONTRACTOR: | DATE:           |

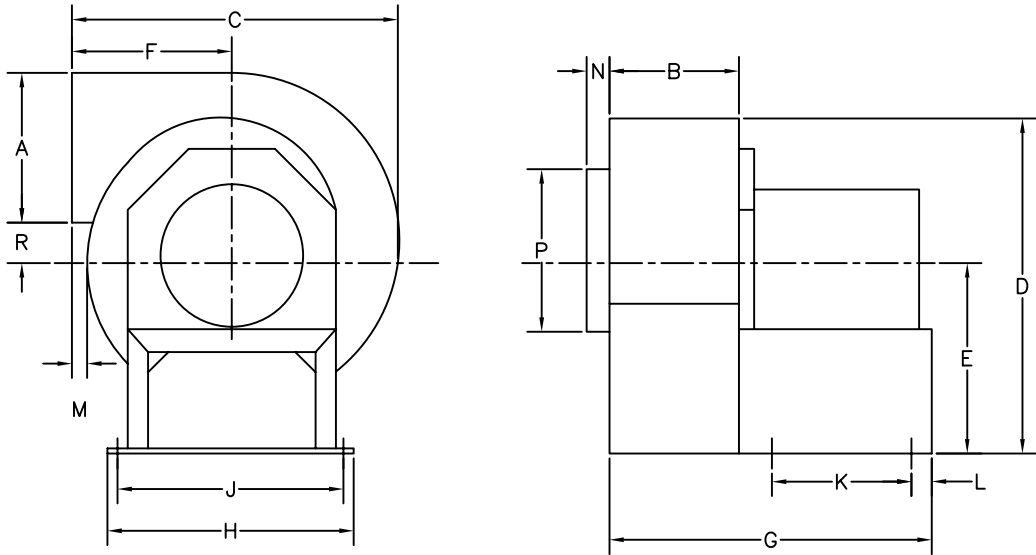

| MODEL  | MOTOR H.P. | BLOWER RPM | PERFORMANCE - C.F.M |           |           |           |         |             |         |             |         |             |         |             |         |
|--------|------------|------------|---------------------|-----------|-----------|-----------|---------|-------------|---------|-------------|---------|-------------|---------|-------------|---------|
|        |            |            | 1/4" S.P.           | 3/8" S.P. | 1/2" S.P. | 3/4" S.P. | 1" S.P. | 1-1/2" S.P. | 2" S.P. | 2-1/2" S.P. | 3" S.P. | 3-1/2" S.P. | 4" S.P. | 4-1/2" S.P. | 5" S.P. |
| 8BIDD  | 1/2        | 3450       | 840                 | 835       | 830       | 806       | 780     | 712         | 645     | 560         | 453     | 200         | -       | -           | -       |
| 9BIDD  | 1/2        | 3450       | 900                 | 880       | 866       | 840       | 810     | 750         | 687     | 625         | 550     | 475         | 345     | -           | -       |
| 9BIDD  | 3/4        | 3450       | 1198                | 1175      | 1155      | 1120      | 1080    | 1000        | 915     | 830         | 735     | 630         | 460     | -           | -       |
| 10BIDD | 1          | 3450       | 1577                | 1560      | 1535      | 1502      | 1469    | 1390        | 1313    | 1210        | 1100    | 980         | 860     | 580         | 470     |
| 10BIDD | 1-1/2      | 3450       | 1900                | 1880      | 1850      | 1810      | 1770    | 1675        | 1575    | 1460        | 1330    | 1190        | 1040    | 710         | 575     |

| MODEL  | WHEEL                           | BORE                        | A                               | B                                | C                                | D                               | E                               | F                                | G                               | H                               | J  | K | L                              | M                               | N                              | P                              | R                               |
|--------|---------------------------------|-----------------------------|---------------------------------|----------------------------------|----------------------------------|---------------------------------|---------------------------------|----------------------------------|---------------------------------|---------------------------------|----|---|--------------------------------|---------------------------------|--------------------------------|--------------------------------|---------------------------------|
| 8BIDD  | 8- <sup>3</sup> / <sub>8</sub>  | <sup>5</sup> / <sub>8</sub> | 7- <sup>3</sup> / <sub>8</sub>  | 6- <sup>11</sup> / <sub>32</sub> | 14- <sup>7</sup> / <sub>16</sub> | 16- <sup>1</sup> / <sub>2</sub> | 9- <sup>3</sup> / <sub>8</sub>  | 6- <sup>3</sup> / <sub>4</sub>   | 15- <sup>7</sup> / <sub>8</sub> | 12- <sup>1</sup> / <sub>8</sub> | 11 | 7 | 1- <sup>1</sup> / <sub>8</sub> | 1- <sup>3</sup> / <sub>16</sub> | 1- <sup>3</sup> / <sub>4</sub> | 7- <sup>7</sup> / <sub>8</sub> | 1- <sup>1</sup> / <sub>4</sub>  |
| 9BIDD  | 9- <sup>3</sup> / <sub>16</sub> | <sup>5</sup> / <sub>8</sub> | 7- <sup>3</sup> / <sub>8</sub>  | 6- <sup>11</sup> / <sub>32</sub> | 14- <sup>7</sup> / <sub>16</sub> | 16- <sup>1</sup> / <sub>2</sub> | 9- <sup>3</sup> / <sub>8</sub>  | 6- <sup>3</sup> / <sub>4</sub>   | 15- <sup>7</sup> / <sub>8</sub> | 12- <sup>1</sup> / <sub>8</sub> | 11 | 7 | 1- <sup>1</sup> / <sub>8</sub> | 1- <sup>3</sup> / <sub>16</sub> | 1- <sup>3</sup> / <sub>4</sub> | 7- <sup>7</sup> / <sub>8</sub> | 1- <sup>1</sup> / <sub>4</sub>  |
| 10BIDD | 10- <sup>5</sup> / <sub>8</sub> | <sup>5</sup> / <sub>8</sub> | 8- <sup>3</sup> / <sub>16</sub> | 8- <sup>3</sup> / <sub>16</sub>  | 16- <sup>5</sup> / <sub>8</sub>  | 18- <sup>1</sup> / <sub>8</sub> | 10- <sup>5</sup> / <sub>8</sub> | 7- <sup>15</sup> / <sub>16</sub> | 18                              | 14                              | 13 | 7 | 1- <sup>1</sup> / <sub>8</sub> | 1- <sup>1</sup> / <sub>4</sub>  | 1- <sup>3</sup> / <sub>4</sub> | 9- <sup>7</sup> / <sub>8</sub> | 1- <sup>9</sup> / <sub>16</sub> |

### SCHEDULE

| ITEM | QTY | MODEL | HP | CFM | SP [W.G.] | ELECTRICAL | ROTATION/DISCHARGE | REFERENCE |
|------|-----|-------|----|-----|-----------|------------|--------------------|-----------|
|      |     |       |    |     |           |            |                    |           |
|      |     |       |    |     |           |            |                    |           |
|      |     |       |    |     |           |            |                    |           |

**FEATURES:**

- WHEEL BACKWARD INCLINED
- BLADES AND FRONT PLATE - .060" ALUMINUM
- BACK PLATE - .125" ALUMINUM
- DYNAMICALLY BALANCE FOR EFFICIENT OPERATION WITH MINIMAL NOISE.
- HOUSING - 18 GAUGE STEEL WITH BAKED ENAMEL FINISH.
- CCW - THD DEFAULT